

Algorithm. Finding the Maximum Element in a Finite Sequence.

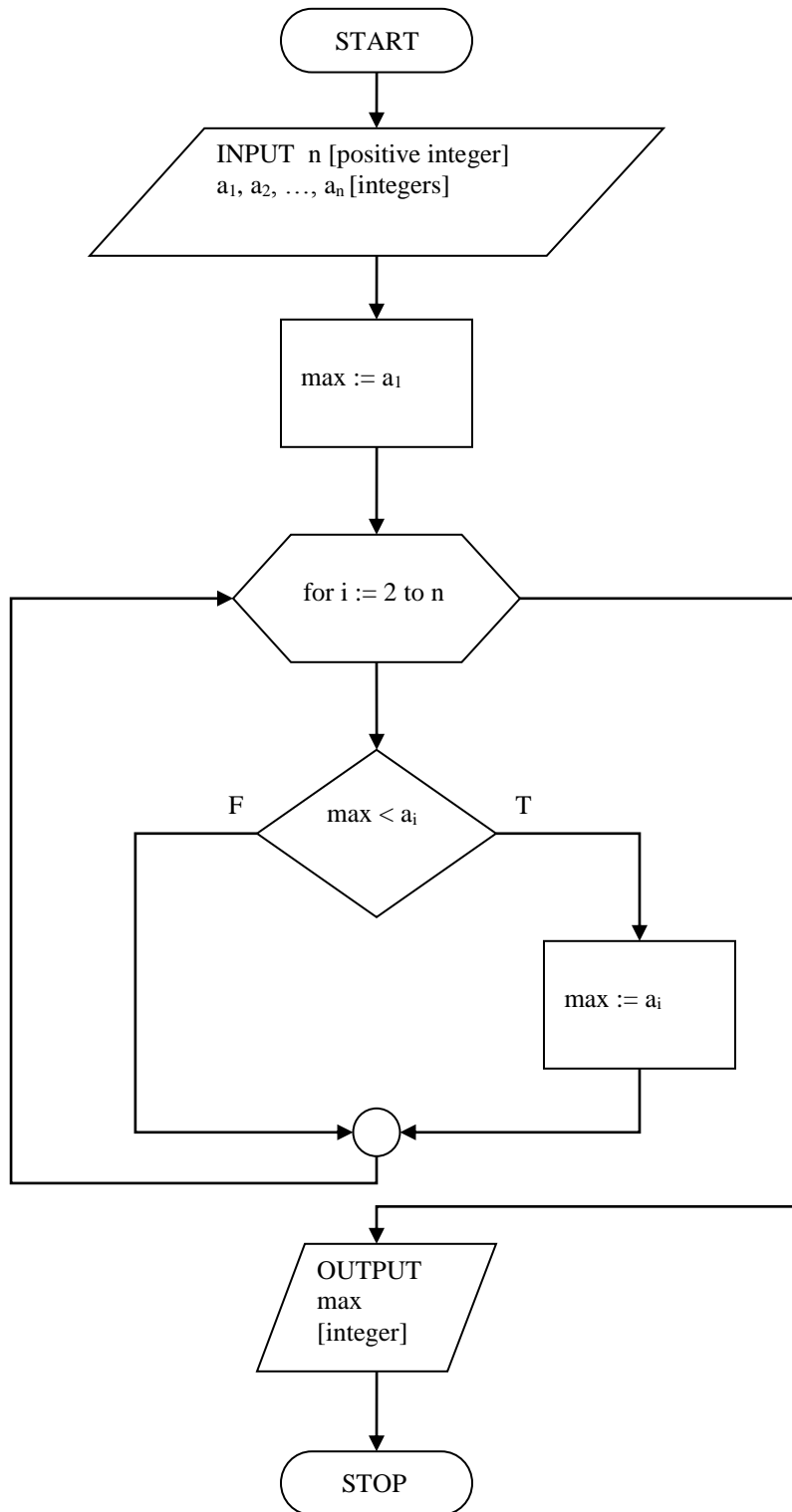

Algorithm. Linear Search Algorithm.

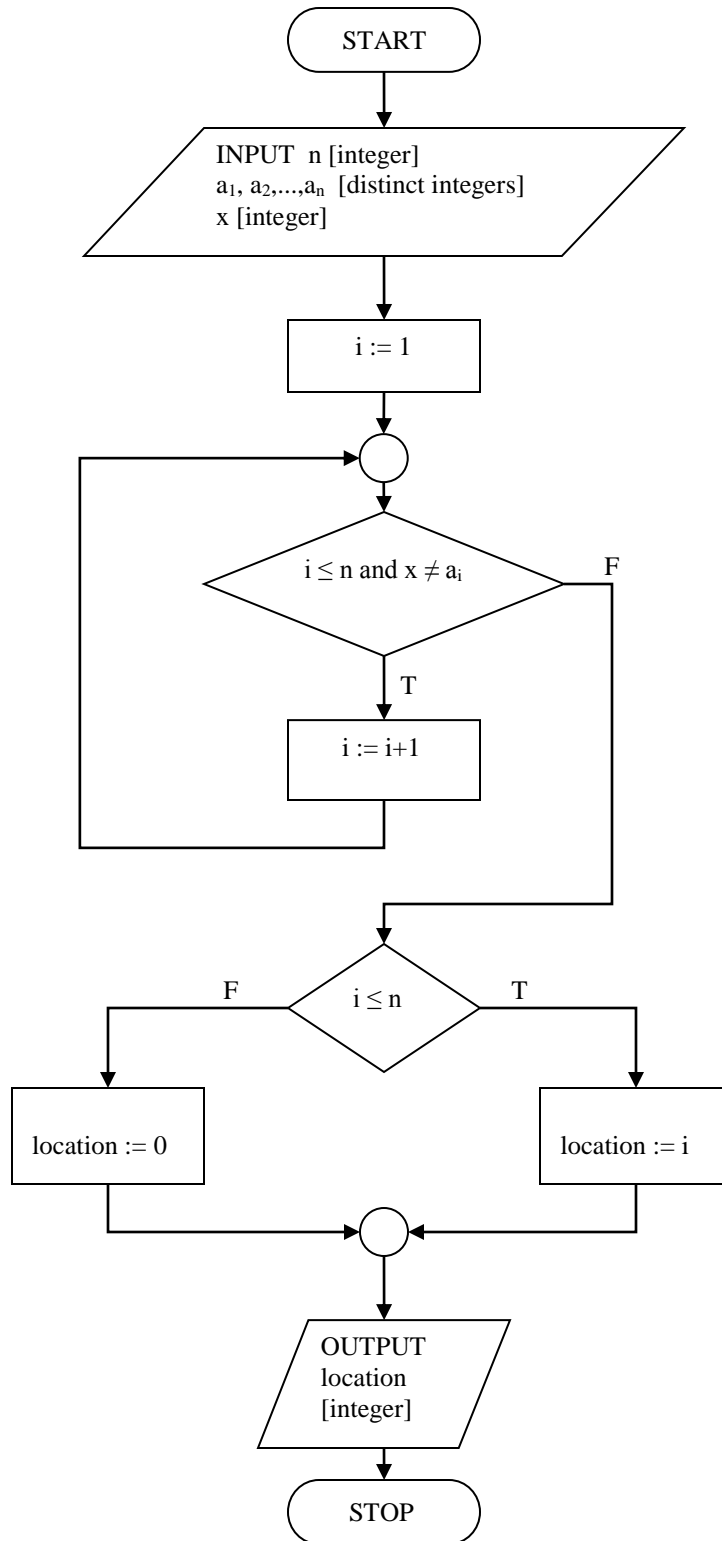

Algorithm. Binary Search Algorithm.

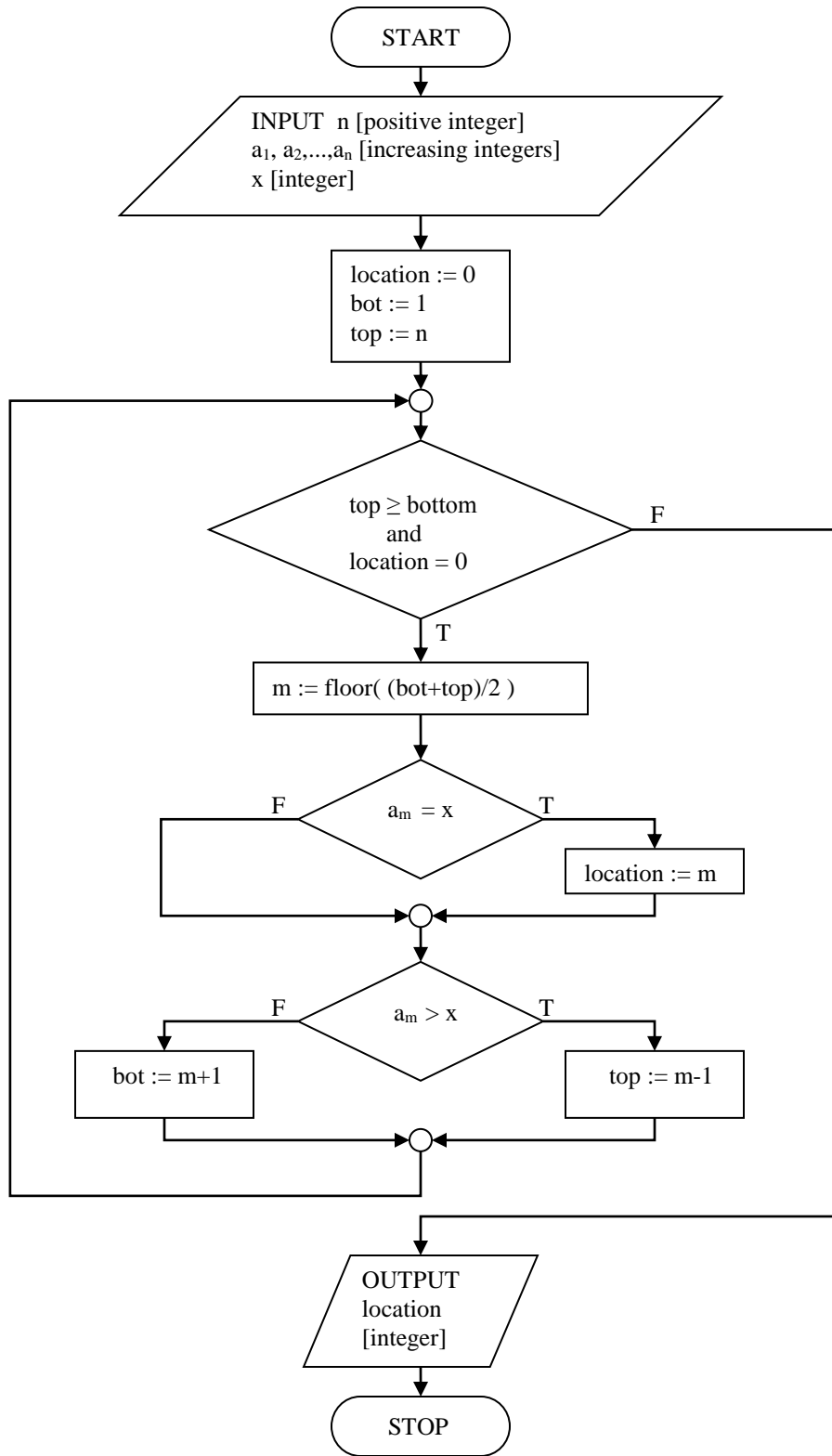

Algorithm. Division Algorithm.
(Positive divisor, nonnegative dividend.)

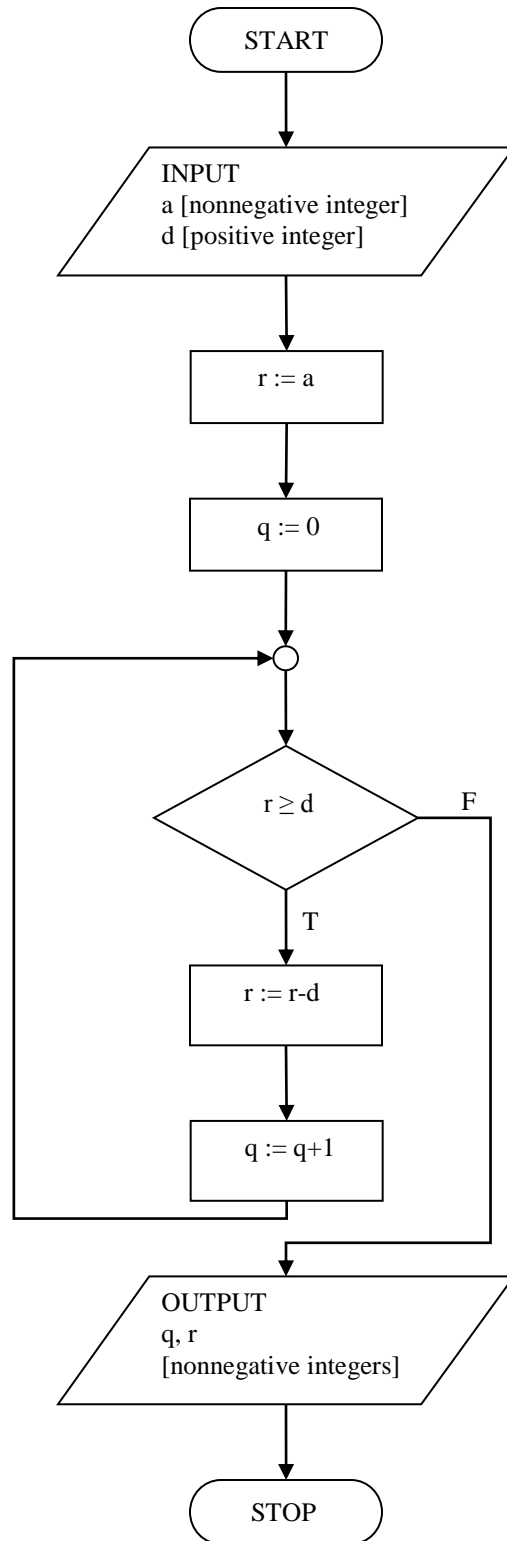

Algorithm. Computing gcds by Subtraction.
(Finds greatest common divisor of two positive integers.)

